

ELECTRONIC  
**BIG TRAK**  
**TRANSPORT**

**OPERATOR'S MANUAL**



## BATTERY INSTALLATION

1. Locate the battery box (see *Fig. 1*) on the bottom of the Transport. Remove the battery cover as directed on the cover.
2. Insert one "D" cell battery (alkaline type recommended) in the battery compartment. Match the charge marked on the battery terminals with the charge marked on the inside of the battery compartment.
3. Replace the cover.

## BATTERY LIFE

When the battery is losing power, the dump action will be slow even if the Transport is empty or is carrying a light load. Replace the old battery with a fresh "D" cell alkaline type battery.

## LABELING DIRECTIONS

Easy-to-apply labels are included for added detail. Labels are numbered and the correct positions are indicated in the following illustration. Peel off labels one at a time and apply as shown in *Fig. A*. After labels are applied, rub down firmly.

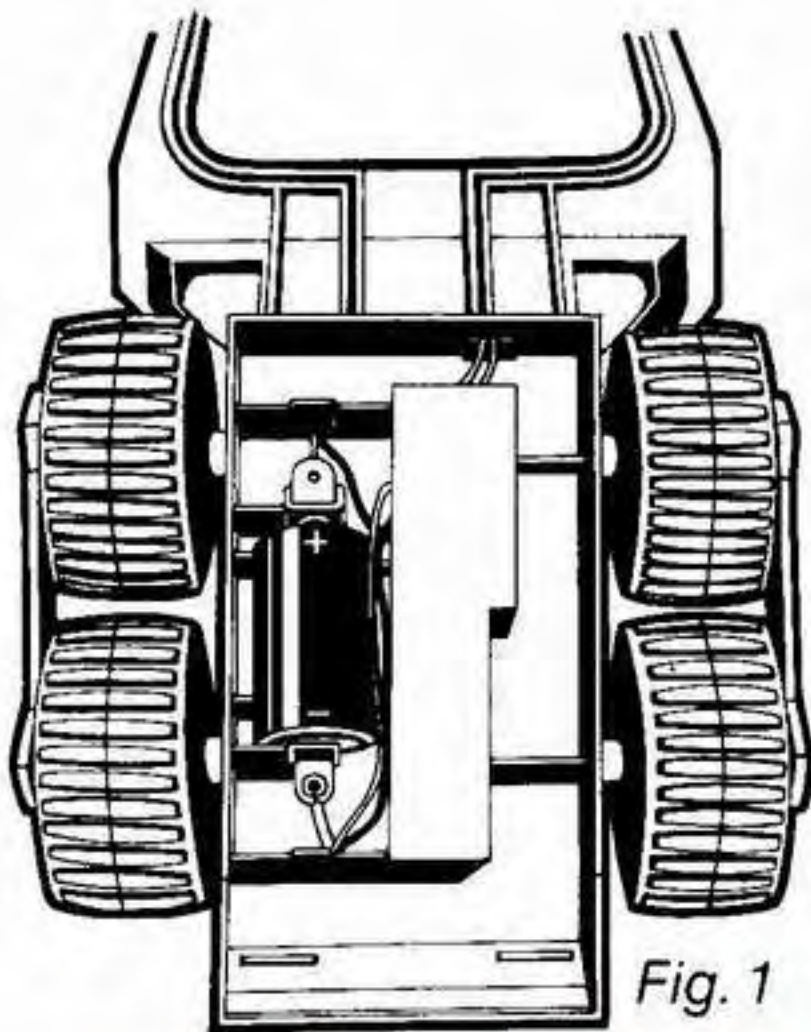

*Fig. 1*

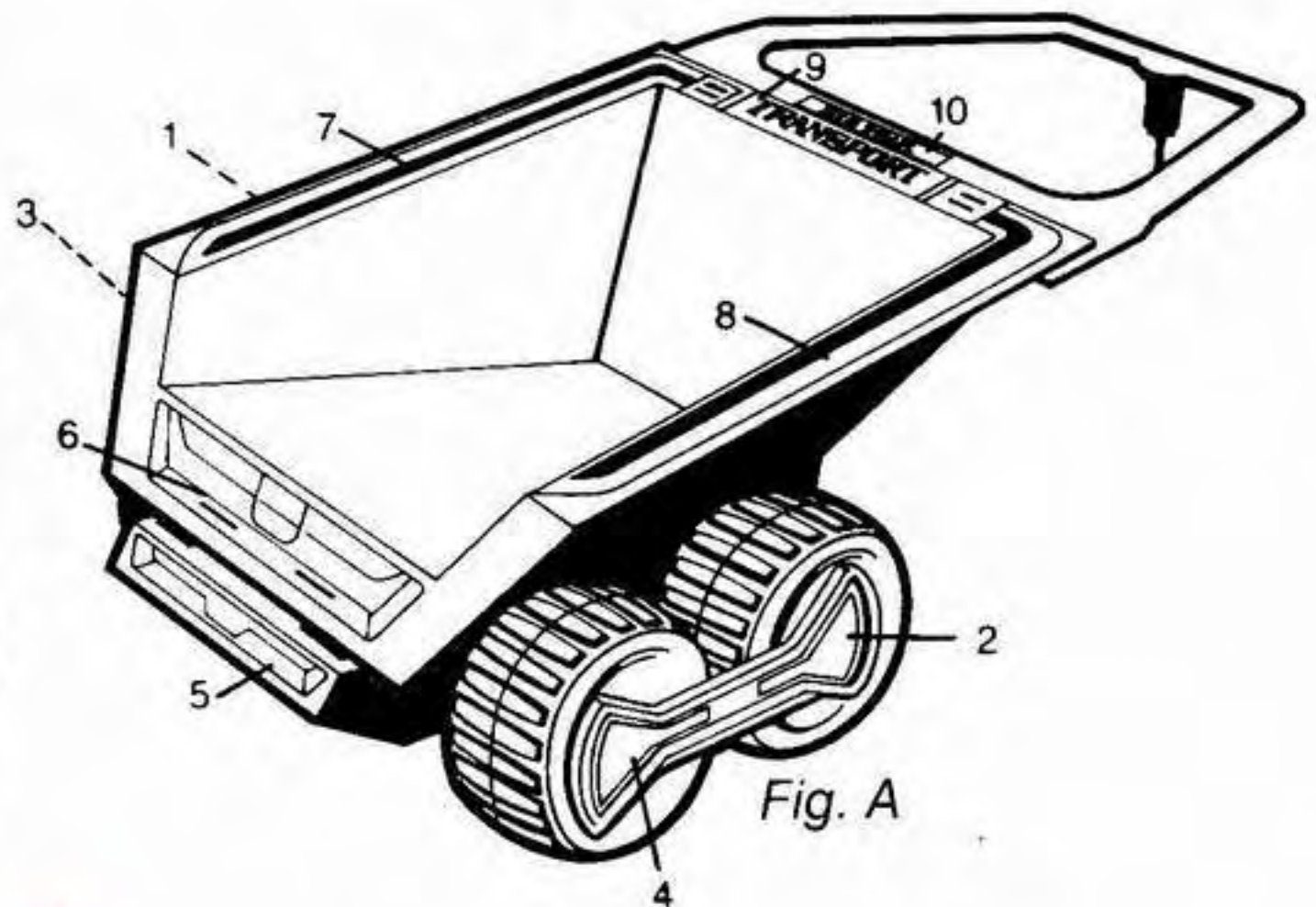

*Fig. A*

## OPERATING INSTRUCTIONS

1. To attach the Transport to Big Trak, refer to the illustration on the back of the box. Slide the "door" covering the opening on the top of Big Trak to one side as shown.



2. Insert the Transport plug into the opening and push in. Be sure to attach the Transport **before** you begin programming Big Trak or you may erase some of your steps.  
Note: Even with Big Trak turned off, the Transport may lift up when you attach it to or remove it from Big Trak. Therefore, you should wait until the Transport is attached before you load the dump section.
3. Once the Transport is attached, check the connection by pressing **TEST** on Big Trak's keyboard. Big Trak will go forward two lengths, fire three times, activate the Transport's dump action, and go backward two lengths.  
Note: If the Transport does not lift up during this test program, refer to the independent test section later in the booklet.
4. If the test program was successful, you are ready to enter your program. The Transport's dump section is activated by pressing the **OUT** key.
5. You can press the **OUT** key at any point in the program and you can use this function more than once in the same program.
6. Pressing the **OUT** key causes Big Trak to pause for approximately five seconds for the dumping cycle.  
Note: When your battery is new and the dump section is empty, it may lift twice.
7. The maximum weight the Transport can lift is about one pound. If the load is near the weight limit, Big Trak may go on to the next step before the dumping cycle is completed. If the load is too great, the dump section will not lift up—OR—the dumping cycle may begin then stall with the dump section partially raised. Lighten the load until the Transport can complete the cycle easily.  
Note: Do *not* force the Transport up or down by hand. It must move *only* on its own power.
8. The Transport will follow Big Trak on any maneuver. When Big Trak backs up over three or four feet, the Transport will veer off to one side much like a trailer.

### **SPECIAL CAUTION**

Do *not* lift the Transport off the ground while it is attached to Big Trak as the plug will break. If the unit goes under a piece of furniture, for example, simply *slide* it out from underneath—being sure not to lift the wheels off the floor.

### **INDEPENDENT TEST:**

If your Transport does not dump during the test program, try the following steps to determine the source of the malfunction.

1. Disconnect the Transport from Big Trak. Be sure that all of Big Trak's batteries are fresh and properly connected. Then test Big Trak by itself to make



sure it is operating properly. Refer to your Big Trak instructions to make this test.

2. Now test the Transport by itself (not connected to Big Trak). Make sure the Transport has a fresh battery that is properly connected with both terminals making good contact. Then, make a temporary connection on the Transport plug (See Fig. 2) by pressing a metallic object (such as a paper clip) firmly against the two areas shown at the same time. Hold it there for several seconds.
3. If the Transport completes the dumping cycle using this temporary connection and Big Trak is operating properly, connect the two together (make sure the plug is securely inserted into the opening) and press the **TEST** key again.
4. If the Transport still does not dump, the problem is with Big Trak. Consult your Big Trak instructions for warranty rights and repair services.

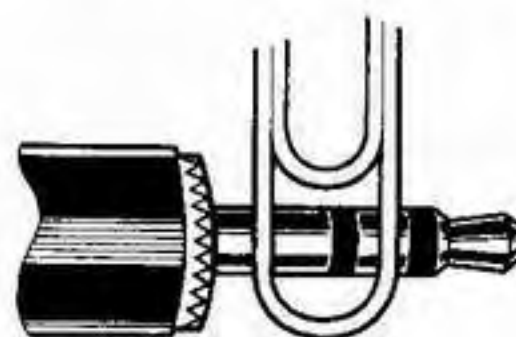

Fig. 2

### **90 DAY LIMITED WARRANTY ON BIG TRAK TRANSPORT**

Electronic Big Trak Transport is warranted by Milton Bradley Company to the original purchaser for a period of 90 days from the original purchase date under normal use and service against defective workmanship and materials (battery excluded).

This warranty is void if Big Trak Transport has been damaged by accident or unreasonable use, neglect, misuse, abuse, improper service or other causes not arising out of defects in workmanship or materials.

Milton Bradley shall not be liable for loss of use of Big Trak Transport or other incidental or consequential costs, expenses or damages incurred by the purchaser. Some states do not allow the exclusion or limitation of incidental or consequential damages, so the above limitation or exclusion may not apply to you.

During the warranty period, if found to be defective due to workmanship or materials, Big Trak Transport will either be repaired or replaced with a reconditioned product of an equivalent quality (at Milton Bradley's option) without charge to the purchaser when returned with proof of purchase date, shipping prepaid to the address listed below. In the event that Big Trak Transport is replaced, the warranty on the replacement will be continued for 90 days.

This warranty gives you specific legal rights and you may also have other rights which vary from state to state.

#### **Post Warranty Repair Policy**

After the 90 day warranty period has expired, Milton Bradley shall, for a period of one year from the date of purchase, either repair your product or replace it with a

reconditioned Big Trak Transport on the condition that you return your product, shipping prepaid, to the address listed below along with proof of purchase date and your check or money order in the amount of \$5.00. Milton Bradley shall not be obligated to perform this service if Big Trak Transport has been abused, misused, improperly serviced or damaged due to accident.

#### **General Instructions**

**IMPORTANT** — Before returning Big Trak Transport for repair, we recommend that you test your product with fresh, strong batteries. Even new batteries may be defective or weak and low battery power is a frequent cause of unsatisfactory operation.

### **MAILING INSTRUCTIONS PLEASE READ CAREFULLY AND RETAIN THIS IMPORTANT INFORMATION FOR FUTURE REFERENCE**

#### **REMOVE THE BATTERY — DO NOT RETURN IT**

If the original packaging is available, repack Big Trak Transport in its packing and box. If not available, wrap carefully, making sure to surround the product with adequate padding. If the 90 day warranty period has expired and your purchase date is still within our one year time limit, send in \$5.00 and proof of purchase. Please include a brief description of the problem, your return address and mail postage prepaid and insured to the following address. Do not send the battery with Big Trak Transport.

**Milton Bradley Company  
Attn: Electronic Quality Control  
\*Building 104-A, Lincoln Street/Federal Square  
Springfield, MA 01105**