

OPERATING INSTRUCTIONS

BATTERY LOADING:

(FOR MAXIMUM PERFORMANCE, USE ALKALINE BATTERIES. (NOT INCLUDED))

Remember to take out the batteries after playing.

- Do not mix old and new batteries.
- Do not mix alkaline, standard (Carbon-Zinc) or rechargeable (Nickel-Cadmium) batteries.

INSTALLING THE BATTERIES:

1. Unscrew to open the Battery Case Cover of the base of the robot.
2. Insert 6 'C' size alkaline batteries as indicated inside following the (+) (-) signs polarity. (See Diagram 1)
3. Replace the Battery Case Cover.

ATTACHING THE REAR WHEEL:

Push and slide the rear wheel into the back of the robot. (See Diagram 2)

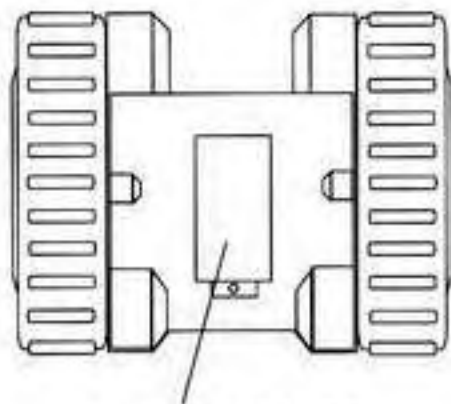

BATTERY COVER
(Diagram 1)

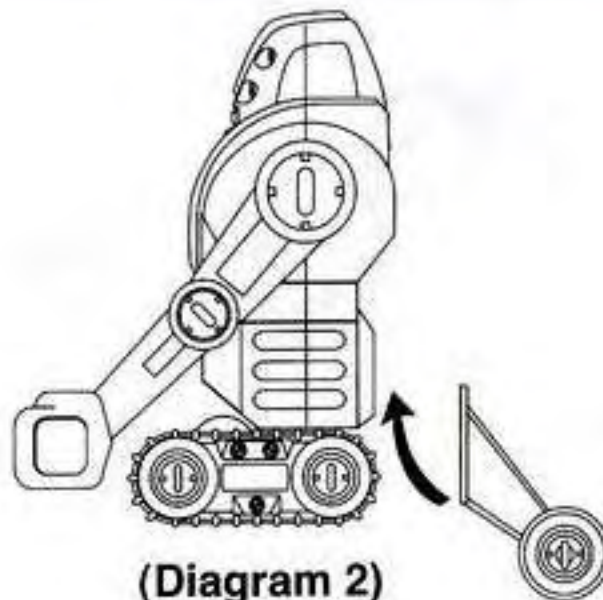

(Diagram 2)



TRACK MOVEMENT

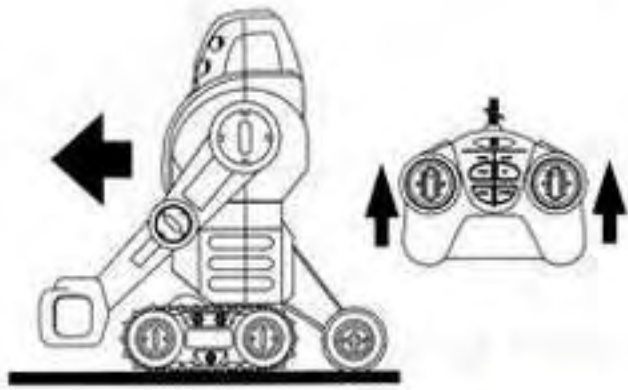

Move Forward

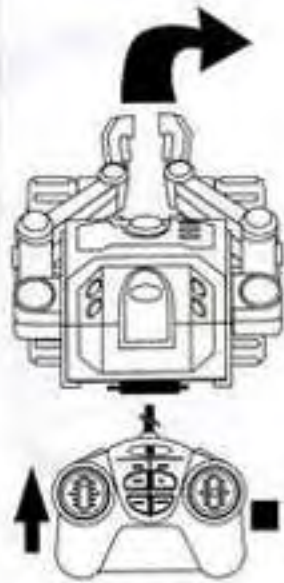

Turn Right (Forward)

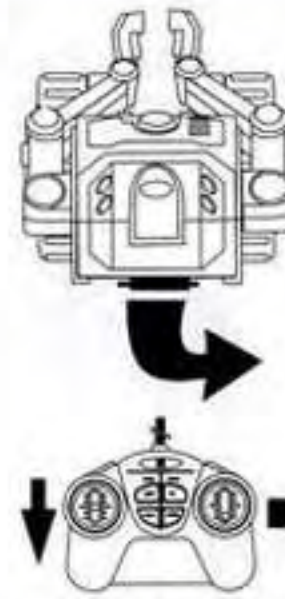

Turn Right (Backward)

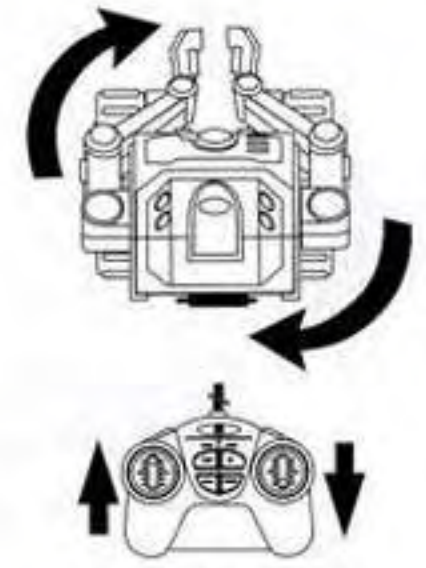

Rotate Right

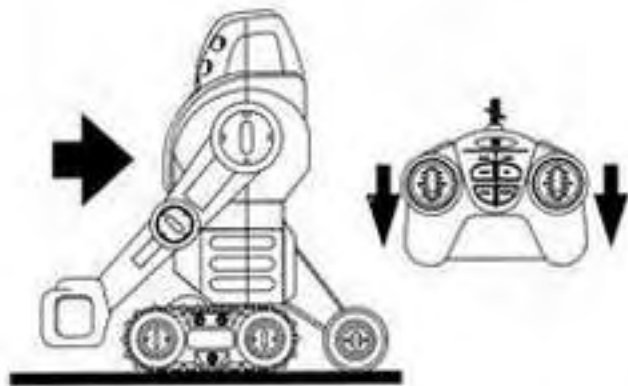

Move Backward

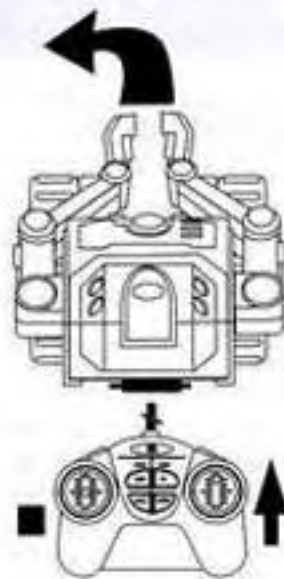

Move Left (Forward)

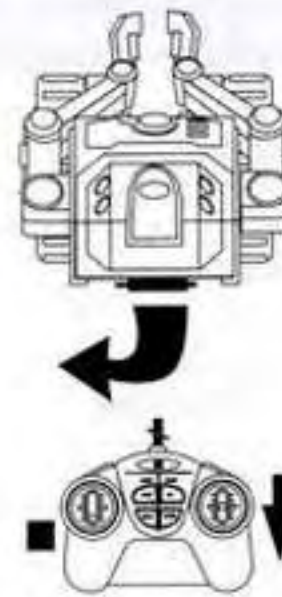

Move Left (Backward)

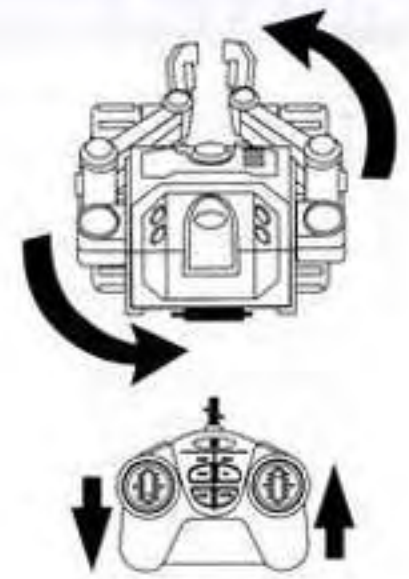

Rotate Left

ARMS MOVEMENT

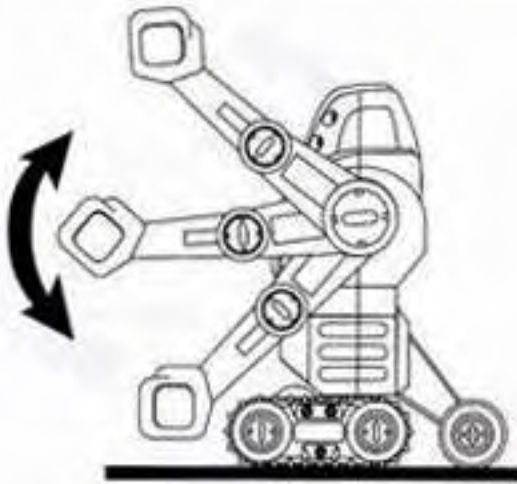

Arms Up & Down

Press UP & DOWN buttons to move the arms

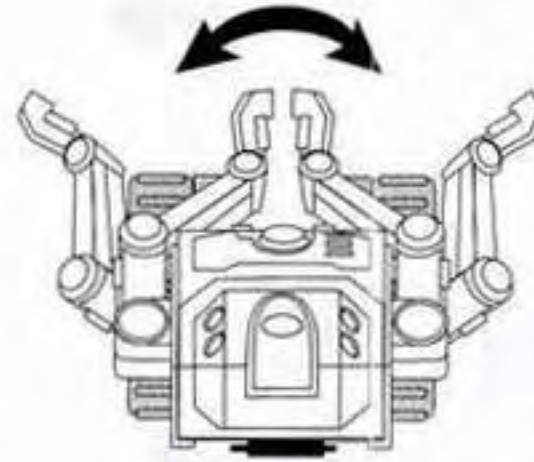

Arms Open & Close

Press OPEN & CLOSE buttons to move the arms

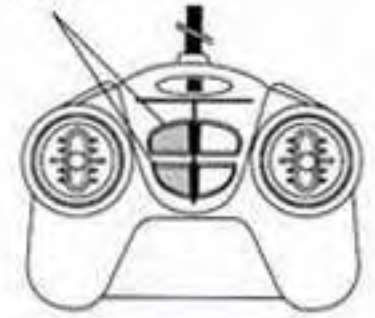

HINTS FOR BETTER PERFORMANCE

TROUBLE	REASON	INSTRUCTION
<ul style="list-style-type: none"> When robot runs in opposite direction from your command. 	<ul style="list-style-type: none"> Misplacement of batteries. 	<ul style="list-style-type: none"> Place batteries as marked (+)(-) in battery compartment.
<ul style="list-style-type: none"> When robot does not operate properly or does not move. 	<ul style="list-style-type: none"> Insufficient battery contact due to rust. 	<ul style="list-style-type: none"> Remove rust with sand paper or a clean cloth.
<ul style="list-style-type: none"> When robot goes too slow. 	<ul style="list-style-type: none"> Batteries too weak. 	<ul style="list-style-type: none"> Replace with new batteries.
<ul style="list-style-type: none"> When flashing light goes dim. 	<ul style="list-style-type: none"> Batteries too weak. 	<ul style="list-style-type: none"> Replace with new batteries.

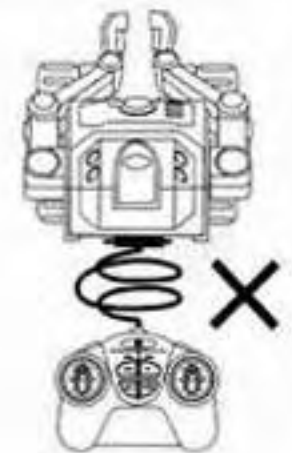
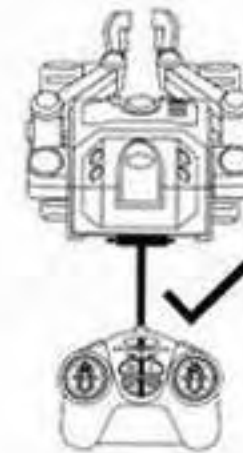

SPOT LIGHT

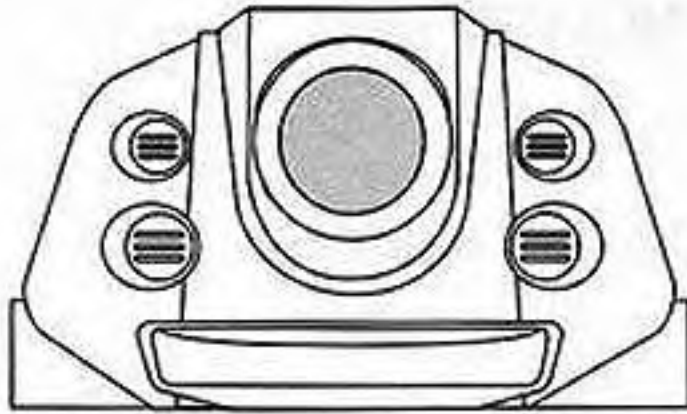

Spot light comes "ON" while Robot runs forward and backward or turns left and right

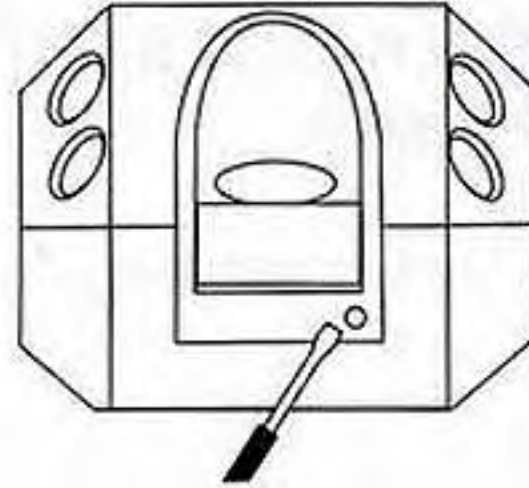

If the Spot Light is out of order, Unscrew to open the case cover and replace the light bulb. (8V base type: E10)

THE CONTROLLER

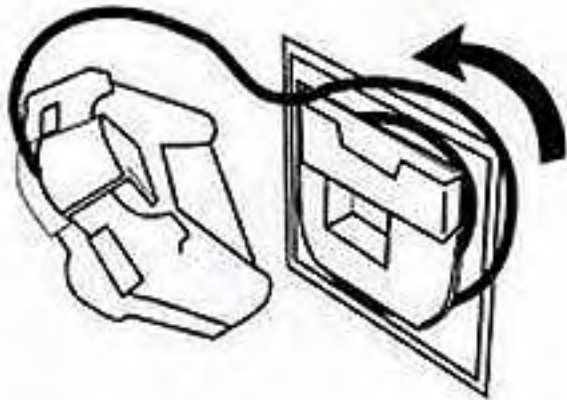

Step 1

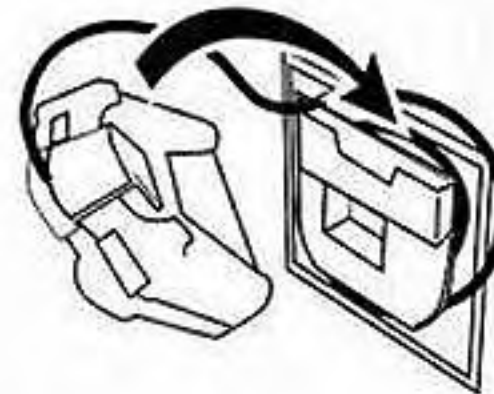

Step 2

After playing, wrap the cable around the controller holder at the back of the robot to store the controller.